

# Façade Cleaning Robot for the Skyscraper

Thomas Bock, Alexej Bulgakow, Shigeki Ashida

The Chair for Realization and Informatics of Construction  
The Faculty of Architecture, Technical University of Munich  
Arcisstr. 21 80333 Munich, Germany, Tel. +49-89-289-22100, Fax. +49-89-289-22102  
Email: [Thomas.bock@bri.ar.tum.de](mailto:Thomas.bock@bri.ar.tum.de) : [bulgakow@bri.ar.tum.de](mailto:bulgakow@bri.ar.tum.de) : [ashida@bri.ar.tum.de](mailto:ashida@bri.ar.tum.de)

**ABSTRACT:** Considering all available basic conditions, a semiautomatic cleaning version can be best implemented under technical, organizational and economic constraints. All cleaning processes are executed by means of a service robot. The robot is controlled by just one operator. The cleaning quality of surface remains constantly excellent and the cleaning efficiency increases significantly.

**KEYWORDS:** Cleaning Robot, Façade cleaning, Semiautomatic, Vacuum suction, Nacelle traveling, Skyscraper

## 1. INTRODUCTION

The façades of skyscrapers have to fulfill above all a representative function for the companies. The appearance of the surface of facades plays thereby for the entire corporative identity. The environmental impact results in an intensive contamination of facades. The modern building materials react quite differently to influences of the climate. Even high-quality natural stone facades attract visible tracks of the pollution. Therefore facade surface must be cleaned regularly. The frequency of the cleaning can be executed in the cycle of decades depending on degree of pollution. The cleaning cycle and intensity are determined by economic constraints. Recently self-cleaning glass facades are available. But as far as existing façade are concerned a reduction of labor cost share by robotic maintenance is required. The higher the degree of pollution is, the more intensive cleaning agents and instruments must be used or shorter cleaning intervals.

The first skyscraper with anodized aluminum facades was built in the seventies in Munich. These facades were offered as maintenance-free. The cleaning was not considered necessary, because the anodic oxide coating is hard and weatherproof. The experience showed however that anodized facades get dirty by environmental strains. A further

important argument for cleaning was not considered likewise; because the more dirty a facade is, the higher is the corrosion grade. Additionally the contamination increases the original surface, which makes it more absorptive and vulnerable for larger quantities of corrosion stress. By neglecting cleaning the façade can deteriorate as far as it will be impossible to keep its original quality. Therefore repetitive low impact maintenance by robotic cleaning anticipates real estate valueless.

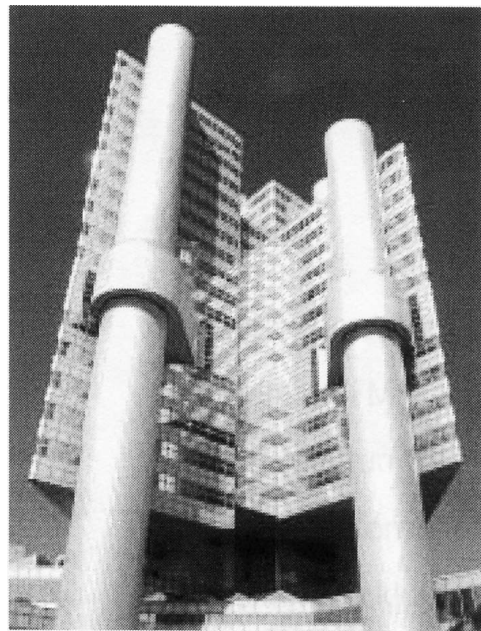

**Photo 1. Skyscraper with anodized facades**

Cleaning of anodized facades by robots is required for the following reasons:

- Reduction
  - of chemical pressure
  - of contamination
  - of structural changes of the original surface
- Cost-profit optimum
  - of maintenance
  - of façade appearance
  - of real estate value

## 2. Kinematic Solutions

### 2.1. The cleaning operation

The basic cleaning of an anodized aluminum surface takes place in two levels: Pre-purifying and main cleaning. Pre-purifying consists in spreading the cleaning agents on the surface and washing off with soft brushes. For the available exterior wall sections it is optimal to use rotary soft brushes. At the same time three exterior wall sections are processed. For the setbacks between the exterior wall sections brushes of an appropriate diameter must be used. These three brushes that are propelled with an electrical servo actuator form the first part of the cleaning and into those one another current waves are accommodated. At the start of the purification process three brushes are inserted into the cracks and three others received meanwhile the contact with the lamella surface. The contact pressure of rotary brushes to the surface can be determined before the cleaning and depends on the degree of pollution of the surface. The solvent is supplied by the conditioning plant and led back by a special suction procedure completely into the system. Thereby a closed cycle is implemented.

The main cleaning of the surface with a cleaning agent is executed with the help of the second section of the cleaning (Fig. 1). The brushes are exactly the same arranged, whereby for the anodized aluminum surface fine wool is used. Both brush series are arranged to each other with a distance from 30 cm. Washing the cleaning agent which arrears off must take place right after the main cleaning, so that the

waste water does not dry up. In addition the third series of cleaning brushes are used. The module with two brush series can be changed, in order to execute the job of a thin water-repellent protective film with following polishing out.

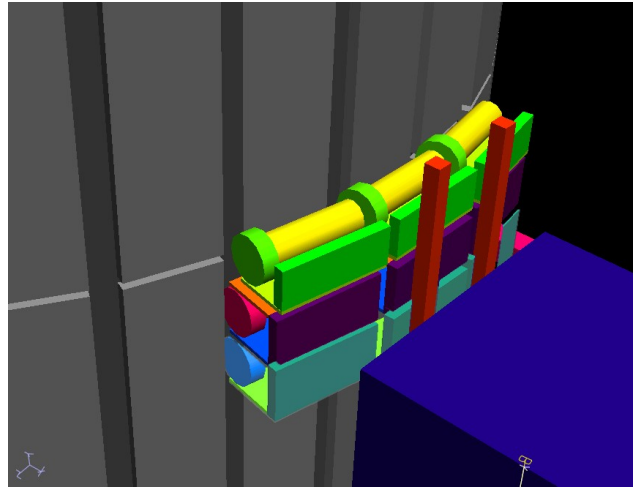
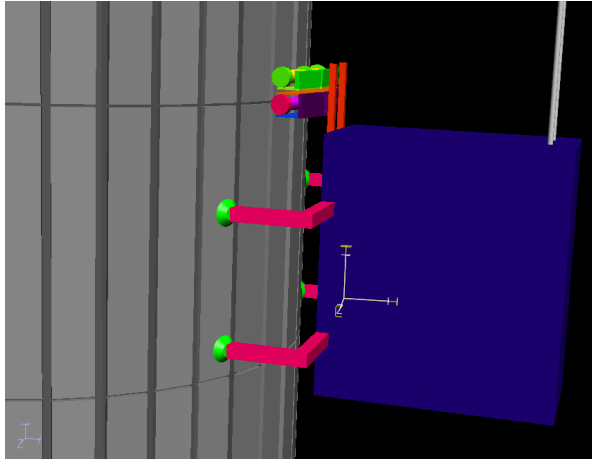

**Fig. 1. Brushes in the Main Cleaning Step**

### 2.2. The robot platform

The mobile platform of the facade-cleaning robot serves as carrier system for the cleaning operation. The necessary contact pressure to four telescope rods with vacuum plate to the facade surface is ensured at the cleaning process. Additionally they enable an occurring of the back-up ring constructions of the towers (Fig. 2).

Beside the cleaning brushes on the platform the spray nozzles are arranged for the job of a water-repellent protective film. This platform does not need guide rails at the facade, presupposed the robot autonomously, without nacelle. The progressive movement of the robot can take place via a successive separation and new positioning of each of the four suction cups. The switch-selectable bars form a basic yoke construction for the robot. This construction is completed by two rails for the progressive movement of the cleaning operation. All components of the kinematics are coordinated. The robot can be operated in automatic and semiautomatic process and used at different facades. The load entry into the facade is small. The two-coordinate construction of the robot can be served



**Fig. 2. Structure of the Mobile Platform**

quite easily. This kinematic pattern of the facade cleaning of robot presupposes itself a problem-free in the fulfillment of safety requirements.

### 3. Applying concept

#### 3.1. Implementation

Considering all of available basic conditions, a semiautomatic cleaning version can be best implemented under technical, organizational and economic request. The robot is accommodated thereby on a nacelle of the traveling unit, adjusted while the whole cleaning process to complete and with the transfer of a user (Fig. 3). The function of the user exists in the monitoring of the cleaning process and in the execution of the cleaning of the

facade surface in difficulty accessible zones by hand.

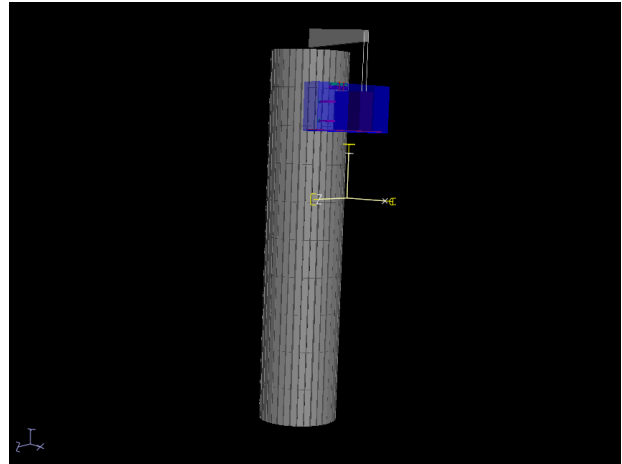

**Fig. 3. Nacelle of the traveling Unit**

The latter enables a simplification of the robot system and thus a cost saving.

The robot can be used also at surfaces of other type, e.g. for the window surface cleaning.

#### 3.2. Application of the cleaning operation

When an electromechanical system (power supply, engines, transmissions) is designated for the drive of the cleaning, it activates the cleaning brushes. The main parameters of the drive are performance, rate, precision, controllability, dimensions, weight and price. The special feature of the electric drive consists of the fact that they are indicated particularly by the small dimensions, an easy control, high precision, maximum stress and reliability (Fig. 4).

**Table 1. Technical data of the façade cleaning robot**

<b>Type of cleaning</b>	Brushes
<b>Brush size</b>	Length: 300 mm Thickness: 50 mm
<b>Drive</b>	Automatic guidance of the cleaning heading
<b>Heading pressure</b>	Manual adjusts
<b>Dressing plant</b>	Negative pressure system
<b>Capacity</b>	4,0 kW
<b>Cleaning performance</b>	50 m <sup>2</sup> /h
<b>Advantages</b>	Small personal expenditure Good and safe cleaning quality
<b>Weight</b>	75 kg

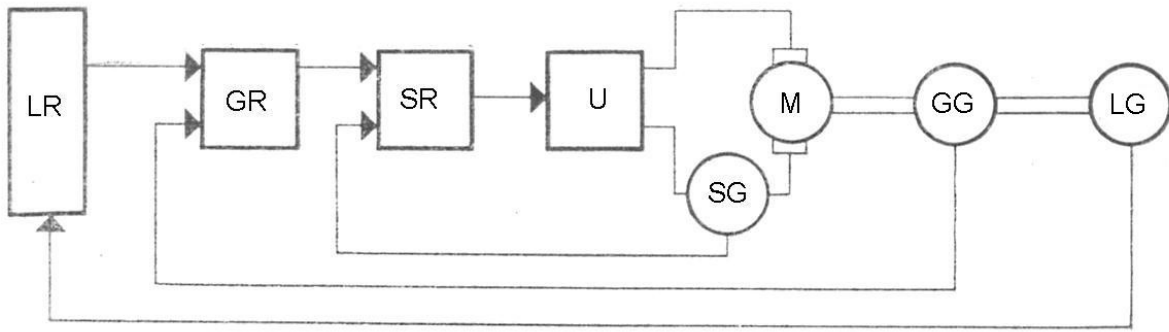

LR ; Position regulator, GR ; Speed regulator, SR ; Power regulator,  
 U ; Converter, M ; Motor, LG ; Position sensor, GG ; Speed sensor, SG ; Power sensor

**Fig. 4. Main Scheme of electrical operation**

Regardless of the relatively low performance and quite high price, the electric motors are the best fit for the cleaning robot of the facade.

### 3.3. Application of the robot platform

The platform of the robot is equipped with a pneumatic drive. The vacuum cups serve above all in order to protect the contact pressure of the robot to the surface during the cleaning process. Additionally they permit a progressive movement in up and downwards along the facade. The robot is held by the wire rope of the traveling unit. The vacuum attraction is stopped normally as a function of the entire mass of the robot, either by the degree of the vacuum or by the number of suction cups. These adjustments will be made before beginning of the work and do not need to be corrected during the job.

Adaptive vacuum cups react completely differently. At the Fig. 5 an appropriate structural variant is represented. The vacuum cup consists of the pneumatic cylinder (1), where the lower output the suction cup is in form of an open vacuum chamber (2). The vacuum chamber is connected through the connecting piece (3) with a vacuum pump. The entire device is connected by the coupling (5) with the lifting machine. The axle (4) forms a link connection to the piston rod (6) of the cylinder. The vacuum chamber has additionally a valve (7), which

is a connection to the outside. Between the housing of the pneumatic cylinder and the coupling the torsion spring (8) is arranged. When releasing the instruction for touching the object, the valve is closed. In the vacuum chamber a vacuum is created by the compressor. If the load (e.g. because of the wind conditions) exceeds the nominal value, the housing of the pneumatic cylinder shifts relative to the coupling downward, the torsion spring stretches, the piston space of the cylinder becomes larger, so

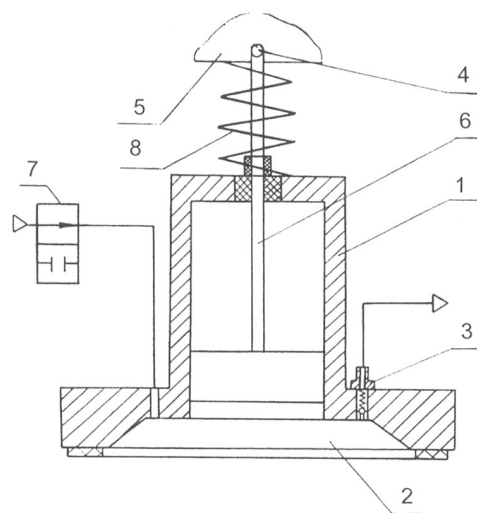

**Fig. 5. Adaptable Vacuum Sucker**

that the vacuum in the vacuum chamber correspond to the load of the robot increases. Suction force

increases, and holding of the robot becomes more reliable. The more largely the difference between the nominal and the actual value of the load, the larger the shifts of the housing of the cylinder, the volume of the piston space and thus the suction force of the grip arm.

### 3.3. Control concept

The facade-cleaning robot can be differently served. In the case of a semiautomatic version the adjustment of the robot is executed in the working position and monitoring of the trial process of a user, who is with the robot in the nacelle of the traveling unit. The robot can be controlled also by means of a remote maintenance (Fig. 6). The parameters of the cleaning are controlled thereby with a monitoring camera and different sensors. The user has the function to start the purification process and react if necessary to occurring messages. A permanent monitoring of the system by the user is not necessary. However the use of a monitoring camera increases substantially the price of the cleaning robot. The electric power supply of the robot can take place by cables or via a cable attached on the nacelle.

## 4. CONCLUSIONS

Considering all of available basic conditions of technical, organizational and economic constraints, semiautomatic cleaning version can be best implemented. The cleaning process is executed by the robot. The check of the process and adjusting the robot are implemented by an operator. The second worker can be saved. The quality of the surface remains constant and the cleaning efficiency increases significantly.

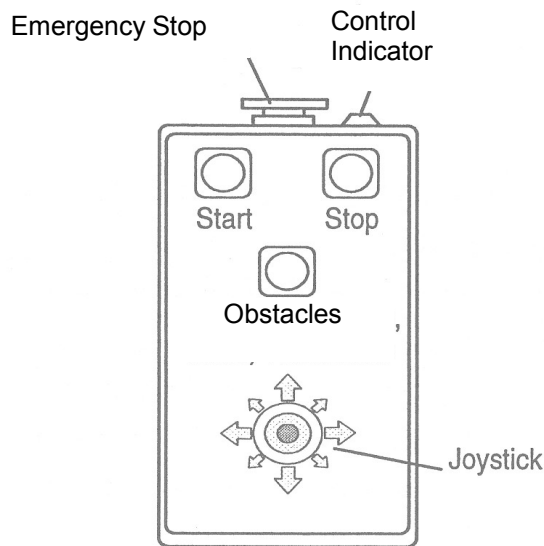

**Fig. 6. Remote Controller**