

COMPUTER TECHNOLOGIES IN CONSTRUCTION ROBOTS CONTROL

Thomas Bock*, Dimitry Parshin**, Rudolf Neudorf**, Alexej Bulgakow*

**Technical University Munich, bulgakow@bri.arch.tu-muenchen.de*

** *Rostov State Building University, RUSSIA, pragma_plus@mail.ru*

Abstract: Construction is of great interest for applying practical and theoretical results in the field of robotics and computer technologies. The paper presents the composition and special features of kinematics and dynamic models of construction robots, control algorithms synthesis in terms of synergetic approach, planning of robot's movements based on computer techniques. Recommendations on computer technologies application, construction robots control, control programmes development and operators teaching are given.

Keywords: automated control system, construction, computer technologies, kinematics, dynamic, model, robot.

1. INTRODUCTION

Construction robotics is of great interest for practical application of the results while performing automation of mounting, finishing, placement of concrete and other kinds of work. However robots application in conditions of construction sites is connected with technological, operational and some other characteristic properties. Successful solution of the tasks dealing with construction operations robotization requires not only the development of special-purpose manipulators but the application of new approaches while solving such problems as control, management and preparation of control programs. In connection with the mentioned above we suggest to use computer technologies in manipulation system control, trajectory path planning, developing routes for handling the parts, developing control programs in the teaching mode, robots analytic programming, robots task-level programming and operators teaching for construction robots taking into account their specific features.

2. MATHEMATICAL MODELS FOR ROBOTS

In the basis of a computer control technology lie mathematical techniques representing the set of models of different levels: from the models of decision making to particular models for carrying out controlled movements of some degrees of freedom. Control algorithms are constructed on the basis of the obtained kinematics and dynamic models. Kinematic models include equations determining position and speeds of the system elements and specifying transport, installation, transfer and orienting movements of construction

robots. The position of coordinate systems while developing kinematic model must ensure conventional representation of mechanisms location and simplify the process of coordinates transformation. For self-mobile construction robots the basic coordinate system $X_m Y_m Z_m$ should be connected with the manipulator rotation axis and the axis X_m is directed along the self-propelled truck.

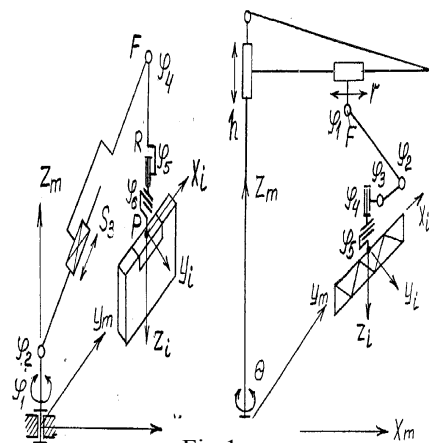

Fig.1

(fig.1). For the rotational degrees of freedom, axes of which are perpendicular to the links (2nd, 4th, 6th pairs) it is convenient to combine axes X_i with rotation axes and axes Z to be led along the link. For the translational degree of freedom and the rotational one with the location of the axis along the link it is necessary to direct axes Z_j along the axes of movement and axes X_j to combine with axes X_{j-1} of the previous degrees of freedom. Direction of coordinate system axes $X_i Y_i Z_i$ of a gripper or a technological tool is defined by a robot. For

mounting robots it is convenient to direct axis Z_i along the end link and axis X_i - along the traverse of the gripping device. In finishing robots we recommend to direct axis Y_i along the end link and axis Z_i to the plane of the mechanism. In this case it is expedient to construct kinematics model on the basis of position T_R and orientation T_{OR} . Using these matrices we can define the position and orientation of the tool: $T_p = T_F \cdot T_{OR}$, and on the basis of this matrix we get the system of equations to determine coordinates of point P in the coordinate system of the robot $X_m Y_m Z_m$:

$$\begin{aligned} X_p &= l_6 \cdot c\varphi_1 s\varphi_5 s\varphi_6 + l_6 \cdot s\varphi_1 c(\varphi_2 + \varphi_4) c \cdot \\ &\varphi_5 s\varphi_6 + (l_5 + l_6 c\varphi_6) s\varphi_1 s(\varphi_2 + \varphi_4) + (S_3 s\varphi_2 + \\ &+ l_4 s(\varphi_2 + \varphi_4)) s\varphi_4; \\ Y_p &= l_6 \cdot s\varphi_1 s\varphi_2 s\varphi_6 + l_6 \cdot c\varphi_1 c(\varphi_2 + \varphi_4) c \cdot \\ &\varphi_5 s\varphi_6 + (l_5 + l_6 s\varphi_6) c\varphi_1 s(\varphi_2 + \varphi_4) + (S_3 s\varphi_2 + \\ &+ l_4 s(\varphi_2 + \varphi_4)) c\varphi_1; \\ Z_p &= l_1 + S_3 c\varphi_2 + l_4 \cdot c(\varphi_2 + \varphi_4) + (l_5 + l_6 c\varphi_6) \\ &c(\varphi_2 + \varphi_4) + l_6 \cdot c\varphi_5 s\varphi_6 s(\varphi_2 + \varphi_4). \end{aligned}$$

where $C\varphi_i = \cos(\varphi_i)$, $S\varphi_i = \sin(\varphi_i)$.

In general manipulator kinematics is represented as a system of equations being the functions of generalized coordinates:

$$\begin{aligned} x_p &= f_1(q_1, q_2, \dots, q_6); \\ y_p &= f_2(q_1, q_2, \dots, q_6); \\ z_p &= f_3(q_1, q_2, \dots, q_6); \\ \theta_p &= f_4(q_1, q_2, \dots, q_6); \\ \beta_p &= f_5(q_1, q_2, \dots, q_6); \\ \alpha_p &= f_6(q_1, q_2, \dots, q_6). \end{aligned}$$

To solve inverse kinematics problems we recommend to use approximate relations based on iteration methods. More exact values of generalized coordinate for a construction robot $q_i^{(k)}$ on k -th step of the iteration cycle are determined through approximate values $q_i^{(k-1)}$ on $k-1$ step:

$$q_i^{(k)} = q_i^{(k-1)} + U_i^{-1} \left[(T_i - T_i^{(k-1)}) + \sum U_{ij} q_j^{(k-1)} \right],$$

where $U_{ij} = \frac{\partial T_i}{\partial q_j}$ is a partial derivative of transformation matrix T_i along the j -th generalized coordinate.

When controlling the robot's movement the data about the speeds of the grip motions and the point defining the transport path of the movement

are necessary. At the given speeds of the manipulator links motions the projections of the tool linear speed are defined by the equations:

$$\begin{aligned} v_x^{(p)} &= \sum_{i=1}^4 \frac{\partial x_p}{\partial \varphi_i} \dot{\varphi}_i + \frac{\partial x_p}{\partial S_3} S_3'; \\ v_y^{(p)} &= \sum_{i=1}^4 \frac{\partial y_p}{\partial \varphi_i} \dot{\varphi}_i + \frac{\partial y_p}{\partial S_3} S_3'; \\ v_z^{(p)} &= \sum_{i=1}^4 \frac{\partial z_p}{\partial \varphi_i} \dot{\varphi}_i + \frac{\partial z_p}{\partial S_3} S_3'. \end{aligned}$$

To simplify the development of kinematic models we suggest to use the method structure decomposition, the essence of which is in breaking the architecture into elementary type structures. This allows to have transformation matrices for each type module that connect its input and output values.

One of the effective methods of modelling dynamic characteristics of robot's effectors is dynamic models construction. According to them we select control algorithms, form optimal laws of control and determine control forces in degrees of freedom. While developing mathematical model for a robot there appears a question about the choice of mathematical device. For construction robots it is convenient to apply motion equations in Lagrangian form. In this case manipulator dynamics is described by a set of interrelated non-linear differential second-order equations of the form:

$$\begin{cases} \sum_{i=1}^6 a_{1i} \ddot{q}_i + \sum_{i=1}^6 b_{1i} \dot{q}_i + \sum_{i=1}^5 \sum_{j=i+1}^6 C_{1ij} \dot{q}_i \dot{q}_j + G_1 = M_1^\Sigma \\ \vdots \\ \sum_{i=1}^6 a_{6i} \ddot{q}_i + \sum_{i=1}^6 b_{6i} \dot{q}_i + \sum_{i=1}^5 \sum_{j=i+1}^6 C_{6ij} \dot{q}_i \dot{q}_j + G_6 = M_6^\Sigma \end{cases}$$

where $a_{ki}(m_i, l_i, q_i)$ - functions characterizing centripetal forces; $b_{ki}(m_i, l_i, q_i)$ and $c_{kij}(m_i, l_i, q_i)$ - functions depending on generalized coordinates and characterizing Coriolis and centrifugal forces; $G_i(q_1, q_2, \dots, q_6)$ - potential forces.

Summary moments acting in degrees of freedom are generally determined by the sum

$$M_k^\Sigma = M_d^{(k)} - M_f^{(k)} - M_l^{(k)},$$

where $M_d^{(k)}$ - moments developed by a drive; $M_f^{(k)}$ - movements of friction degrees of freedom; $M_l^{(k)}$ - movements of external forces. The moment of a drive $M_d^{(k)}$ are defined by the moment of a

motor $M_m^{(k)}$, efficiency $\eta^{(k)}$ and transmission ratio of the drive:

$$M_d^{(k)} = [M_m^{(k)} - J_m^{(k)} \frac{d\omega_k}{dt}] \cdot i_r^{(k)} \eta_d^{(k)},$$

where $J_m^{(k)}$ - moment of inertia of movable parts connected with the motor shaft; ω_k - angular speed. The load moment $M_l^{(k)}$ for each drive is defined by the weight of the working tool and depends on links position:

$$M_l^{(k)} = f(m_l, q_k, q_{k-1}, q_6),$$

A dynamic model developed on the basis of the described equations is added up by the control equations:

$$T_m^{(k)} \frac{dM_m^{(k)}}{dt} + M_m^{(k)} = k_b^{(k)} U_b^{(k)} - k_e^{(k)} \omega_k,$$

where $T_m^{(k)}$ - time constant of a motor anchor chain; $k_b^{(k)}$, $k_e^{(k)}$ - coefficients of transformation and self-induction.

3. ROBOTS CONTROL ALGORITHMS

They include the set of algorithms of motions planning and formation of controls for manipulator degrees of freedom. In performing this the parameters correction of the manipulator motions is carried out discretely in time interval $\Delta(t)$ and the planned trajectory and the laws of changing generalized coordinates provide continuity of the functions, their first and second derivatives. The new values of the motion parameters are generated from the periods of 1-10 ms. An effective principle of developing control algorithms for robots with complex dynamics is a synergetic approach. It is based on separation of motions in complex dynamic systems and approximation of the main properties of the controlled object with a simplified mathematical model. Application of these models with significant non-linearity of the object is limited by states space and time interval. At each interval linearization is permitted and asymptotically stable movement of the system is provided. Such an interval-approximation control possesses robustness as at each control interval adaptation to the properties of the object changing in time and space is ensured. To perform interval-approximation control a dynamic model of a robot as a controlled object is represented by equations of the form

$$\dot{\bar{x}}(t) = F(t, \bar{x}(t), \bar{u}(t)),$$

where F is an allowing approximation vector-function; argument of which are vectors of state $\bar{x}(t)$ and control actions $\bar{u}(t)$. At about point \bar{x}_{i0} and \bar{u}_{i0} of an integrated space of state and input actions we find an approximating dependence

$$F_{ia}(t, \bar{x}_{ia}, \bar{u}(t)),$$

where \bar{x}_{ia} an evaluation vector of the object state with an approximating model in the i -th area of state under consideration. For the interval at the moment t_i we determine χ_i - a vicinity of initial conditions of a state vector $x_{i0} = x(t_i)$ and v_i - a vicinity of current value of a control vector $u_{i0} = u_e(t_i)$, when evaluation error of its own and forced variations of state \bar{x} with of approximation model

$$\bar{x}_{ia}(t) = F_{ia}(i, x_{ia}(t), \bar{u}(t))$$

does not exceed some admissible value

$$\|\bar{\varepsilon}_{ix}(t)\| = \|\bar{x}_{ia}(t) - \bar{x}(t)\| \leq \bar{\varepsilon}_m.$$

This allows to find the values of maximal admissible time interval $\tau_i \in [t_i, t_{i+1}]$ at which the legitimacy of approximation is provided. In this case at $\tau_i \leq \tau_{\max}$ and at exact estimation of the object initial state the control law is calculated according to an approximating model: $\bar{u}(\bar{x}, t) \approx \bar{u}(i, \bar{x}_{ia}, t)$.

Control at an attributed interval τ_i providing stable system movement with the given quality is performed in terms of the methods of optimal model control or methods of the system synthesis according to the desired characteristics. Synthesized control laws $\bar{u}(i, \bar{x}_{ia}, t)$ at the whole temporal control range represent a piece function implementing the algorithm for forming control law with variable parameters. The application of synergetic approach to the motion control of construction robots made it possible to obtain algorithms providing the solution of the control tasks with minimum of calculation operations. This allows to cut down the time for formulating the next vector of control actions, to reduce the interval of renewing control signals and to increase the accuracy of control. The algorithms applied make it possible to form control action according to the given differential equations describing the object to be controlled and the standard transitional processes.

The process of control algorithms development and control program preparation for construction robots is greatly simplified when computer technology is used. Applying methods of mathematical modeling, computer graphics we can perform the search for

optimal trajectories of movements, carry out simulation of the processes of tool motion, provide division of trajectories into sections and form data base of points of control. The robot motions planning is based on non linear control algorithms and carried out with the account of limitations both for the trajectory itself and the manipulator links displacement. Correction of movements parameters is carried out discretely at time interval $\Delta(t)$, and the planned trajectory provides continuity of the function. Values of movement parameters are generated at a period of 1-5 ms. As a result of robot motions planning the obtained laws of changing internal coordinates $q_k[nT]$ are then transformed into control actions $U_k[nT]$ providing motion stability relative to the chosen programmed trajectory. Incorporation of the events processor into the system makes it possible to synchronize the robot's operation with other technological equipment that is especially important for construction-mounting operations.

4. PARAMETERS, CONTROL, PROGRAMS PREPARATION

Construction-mounting operations require constant control of the equipment condition and the technological process parameters. The application of computer technologies allows to obtain information from the sensors about environment situations, means of control concerning the objects positions, to process input data, to display the data by the operator's request at the pre-set period. Visual control of technological operations performance in real time allows to simplify to the utmost the operator's work. Construction – mounting robots should have programs to control the main parameters of movements: the position of each degree of freedom, speed of links movement, gripper (tool) coordinates and speeds of its motion. According to the data read out of position sensors and tachometer generators of the manipulator degrees of freedom tool actual coordinates and its orientation are calculated as well as a vector of tool motions speeds. The calculations are fulfilled on the basis of the algorithms of kinematic model. Meanwhile by operator's request positioning errors can be formed and displayed graphically in the function of time or trajectory.

An important trend in computer technologies application in construction robotics is preparation of control programs which can be carried out outside the construction site on the model of a robot or robotic system. The application of information technologies makes it possible to create a robot's virtual model and a cross-system for preparing and testing control programs and their translation into the codes of the robot control system. A virtual robot which is displayed in 3-D graphics and moves in real time makes up the basis of such system for

developing programs. The developed algorithms and models are put into the basis of the integrated system including the subsystem of 3-D modeling, the system of programming and separate modules for carrying out research and educational tasks. The package of algorithms and programs allows to calculate automatically the positions of all robot's joints participating in performing the pre-set movements, to form control actions and to test their performance on the robot's model. In the process of fulfilling the movements the violation of the introduced limitations for the gripper motion may occur. The characteristic feature of the program developments system is the opportunity of testing control algorithms in different modes with the convenience of imitating the processes of collecting data and control. The described models and algorithms make up the basis of an integrated system of software for civil engineering works. It has a multiwindow interface with functional, graphic and table windows, which can be adjusted to the given kinematic structure. Incorporation of 3-D objects into the user interface makes it possible to simulate visually the operations performed by the robot, to teach the operations.

5. CONCLUSION

The presented material is the result of developments in the field of automation and robotization of civil engineering works. On the basis of the described approaches kinematic and dynamic models construction-mounting and finishing robots have been developed, control algorithms have been synthesized according to synergetic approach to movements control. A software integrated system is of practical interest, it allows to control parameters, visualize robot's work, task in a graphical or table form of movement trajectories, it also provides preparation of programs and operators teaching.

6. REFERENCES

- 1.V. Zagorodnjuc, D.Parchin, The Construction Robotics (Mockow,1990).