

REMOTE CONTROL OF MACHINES FOR REMOVAL OF DAMAGES BEING RESULT OF DISASTERS, WARS, AND TERRORIST ATTACKS

**Adam Bartnicki, Franciszek Kuczarski, Tadeusz Przychodzień,
Andrzej Typiak, Józef Wrona**

*Military University of Technology, Institute of Mechanical Engineering
KALISKIEGO STREET 2, 00-908 WARSAW, POLAND
phone +48 (0-22) 6839419, fax +48 (0-22) 6833211
E-mail: kuczarski@wme.wat.waw.pl*

Abstract: This paper presents an analysis of various natural and civilization disasters being angled as possibilities of usage of the remote control or autonomous machines. There are determined the requirements for such a systems of these vehicles or machines which are able to remove effects of natural disasters and local military conflicts or terrorist attacks. Idea of remote controlled working machines with using of external control, information and observation system is also presented.

Keywords: Remote control, vision systems, machines, disasters

1. INTRODUCTION:

Dangerous events that occur more and more often in contemporary world, being result both natural disasters as well as terrorist attacks (e.g., contaminations, destructions and mining of terrains) and local armed conflicts extort necessity of wide utilization of different machines to remove (or limit) the negative results of them. However, the enormous majority of working machines (excavators, bulldozers, and mobile cranes) or combat engineering machines are used for such tasks being controlled directly by operator (without remote control or computer-aided systems). It is possible to expect that there will occur threats for operators and people who cooperate with them. Hence, we have to very intensely develop the remote control systems for such machines.

On the other hand, implementation the fixed elements on the board of these machines that adapt their to remote or automatic control is not often rational (reasonable) from economic point of view. Hence, taking the attempt to define the general structure of system to adapt these machines for remote control, but only when it is needed, very easily, with limited number of elements installed on the board of machine seems to be reasonable.

It is clear that the core of such a system (transmitter and control desk) and operator should be located out of machine (in safe zone for them).

It also requires to make the suitable outside subsystem of visualization of position of machine and its working equipment, to define their coordinates in coordinate system and to counteract in case of such critical incidents as damage or standstill of machine or troubles with communication between machine and operator (break of transmission of control signals).

The basic efforts of designers of control system of such machines should be focused on minimization of their onboard structure through:

- applying the simple and reliable elements of execution system;
- minimization of range of information transmitted from machine (decreasing the number of sensors and converters);
- introduction the "reliable core" of control system – operating in emergency states;
- possibilities of automatic reconfiguration of onboard system in case of breakdowns and faults.

This extorts necessity of extension of external structure of control system (placed beyond range of direct influence of surrounding of machine (vehicle), what causes:

- necessity of increasing of numbers of transmission channels and speed of sending of information and commands;
- growth of probability of occurring of errors - it requires to amplify signal power for keeping required range of transmission link;
- necessity of elaboration of detailed and complex steering procedures with many variants of operation.

Such designed control system of unmanned vehicles and machines with various extent of automatic and autonomous operation can execute wide range of works such as removal of effects of natural disasters and local military conflicts or terrorist attacks (see table 1).

2. IDEA OF REMOTE CONTROL WITH USAGE OF EXTERNAL CONTROL AND OBSERVATION SYSTEM:

The requirements and conditions which are presented above have allowed to elaborate the idea of remote control of machines with usage of external control and observation system that can be used to remove effects of disasters, wars and terrorist attacks. It has been presented in figure 1. The area of operation has been divided into three zones: basic, supply and expected. In the basic zone a control post has been located. It has been equipped with remote control system to control of machines (1) and (2) and external TV observation cameras with geodesic measurement system of their position, orientation and observation. One of this TV camera is located in supply zone and designated to aid the operation of remained two TV cameras. Both control and vision signals are transmitted via transmission channels. It allows to obtain data concerning position and to control the execution elements e.g. levers, pedals of machines being controlled (1). In adverse conditions remote controlled unmanned vehicles for added observation of machine that is remote controlled in the expected zone can be used. This unmanned, mobile observation vehicle (2) plays the role of relay station for control and information signals between the controlled machine (1) and control post (3).

Standard vision systems perceive the world in two dimensions (because of lack of direct ability to measure the distance to the objects and their size). Thus nowadays the main research problem in

vision system is three-dimensional perception of the picture (particularly its depth). The data of the three-dimensional location of the objects which are not included in two-dimensional picture are included e.g. in stereoscopic pictures.

Stereovision allows to achieve relatively high spatial vision and in comparison with one eye techniques (one-camera) it leads to quantity measurements, more direct and unambiguous. Despite of radar and laser distance measurements it is suitable for many applications. It particularly concerns to reconnaissance, supervision and objects' manipulation in an unknown area detection of vehicles' motion in unknown surrounding, including metric measurement in photogrammetry, robotics and vehicle remote control.

New vision system was elaborated for these needs. The system consists of two basic blocs: observation set and operator position (see figure 2).

Observation set serves to observe the terrain or chosen objects with CCD cameras. Its construction allows to observe chosen objects with both cameras (carrying out stereovision process) or observation the objects located in different directions. At the operator position there are TV cameras, operator panel and microprocessor controller VME.

In the figure 3 the developed conceptual scheme of elaborated vision system is presented. In the system three channels radio link has been applied. Two one direction channels serves to send television signal while two direction channel serves to send steering and measuring signals.

Observation set consists of a steering camera-head mounted symmetrically on a rotary beam. The change of the axis of beam rotation is done by its steering head. GPS system mounted to it reads its azimuth and specifies: set location in geographical coordinates, sea level and terrain slope. The data from GPS might be plotted on digital map which would allow to draw e.g. the route of a vehicle drive (with mounted vision system).

Operator stand allows to control the position of observation cameras, the change of their focal length and focus regulation. Steering might be carried out automatically – with usage of microprocessor controller or in manual way – through operator panel. The data about camera parameters and the location and orientation of observation set are sent to controller and moreover might be shown (in any configuration) on the monitor screen.

Microprocessor controller VME has been designated to automatic control of cameras' position and it is an element supporting the operator. Moreover it enables to process vision signals and determine on the basis of these signals location of observed object in relation to geodesic point of reference. The control procedures of steering cameras' position is used for automatic monitoring the observed object.

3. CONCLUSIONS:

Resulting conclusions from the above schemes and examples indicate that presented idea of remote control vehicles for removal effects of disasters, wars and terrorist attacks is proper. There were underlined the main problems during realization proposed control system i.e. elaboration of visual system for visualization of surrounding of vehicle or its working area. It makes possible the control of such machines in real time by average educated operator.

Presented solutions indicate there is necessary individual approach for designing of structures of control systems in depend on expected technological tasks.

The existing dangerous for human life that have been determined in this paper extort the needs to elaborate the remote and automatic systems for universally used machines and vehicles to make them more safe for operators during works after different kinds of natural and civilization disasters.

Presented vision system can be used for:

- localization of observed objects;
- surrounding observation and detection terrain obstacles;
- observation position and orientation of working equipment;
- visualization of working equipment position.

The additional advantage is that it can be mounted on both engineering machines and separately placed in the terrain.

Its main aim is supporting the operator while fighting or while earthmoving works in inaccessible or hazardous terrain. The assumption of the project was to allow the operator to see working machine (to have with it an eye contact).

On the basis of the picture obtained from cameras both can be specified – vehicle's position and external objects location.

The system may be used in armed forces to locate and indicate the targets as well as to support the fire control at the battlefield.

In further works on the presented system it is assumed that the spatial image will be obtained on the base of data from the observation cameras. It will allow to implement the pictures of observed pictures on TV monitors. Thus the soldiers and the operators of the remote controlled machines and vehicles will be able to perform their tasks more precisely.

4. REFERENCES:

1. Bartha M.; Eibert M.; Schaefer Ch.H.: *Robot-motion in unstructured environment*, Twelfth International Symposium on Automation and Robotics in Construction, Warszawa 1995.
2. Bartnicki A., Konopka S., Kuczarski F., Typiak A.: *Badania doświadczalne sterowania koparką jednonacyniową z systemem wizyjnym*, XV Konferencja Problemy Rozwoju Maszyn Roboczych, Zakopane 2002.
3. Masłowski A.: *Mobilne roboty interwencyjno-inspekcyjne*, Konferencja Automation 97, Warszawa 1997.
4. Bartnicki A., Konopka S., Kuczarski F., Typiak A.: *Remote control of working machines with vision system*, 18 th ISARC International Symposium on Automation and Robotics in Construction, Kraków 2001.
5. Roberts J.M.; Winstanley G.J.; Corke P.I.: *Issues in obstacle detection for autonomous mining and construction vehicles*, 16 th IAARC (IFAC) IEEE International Symposium on Automation and Robotics in Construction, Madrid 1999.

Table 1. Classification of disasters being angled as possibilities of usage of the remote control or autonomous machines*

DISASTERS	
NATURAL	CIVILAZATION
Landslips, earthquakes, volcanic eruptions	Contaminations - radioactive, - chemical, - biological
Floods	Calamities and destructions of objects: - buildings, -communications
Deep snowfalls, snowstorms, blizzards	Fires
Strong winds and hurricanes	Terrorist attacks and different threats of public safety
Long-lasting freeze or droughts, hailstorms or glazes	Destruction damages of infrastructure in result of terrorist attacks and local military conflicts
Plague of rodents and insects	

*) intensity of gray color indicates extent of usage of the remote control or autonomous machines

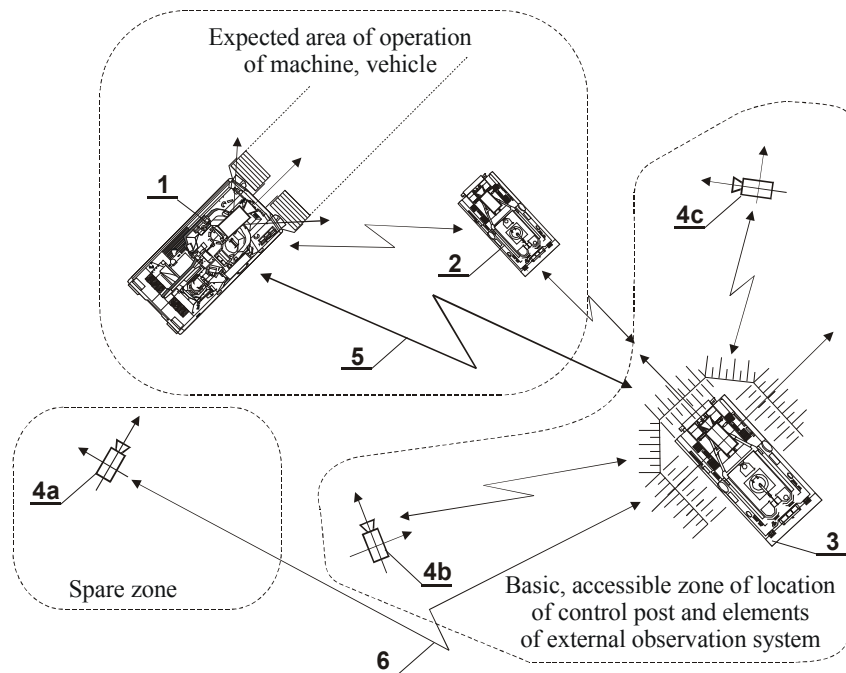

Figure 1. Idea of remote controlled working machines with usage of external control and observation system

1 - machine being controlled; 2 - unmanned, mobile observation vehicle 3 - basic control post (operator equipped with control panel or special vehicle); 4a, b, c - external remote controlled observation

cameras with geodesic measurement system of their position and orientation; 5, 6 - channels for controlling of the cameras and for transmission of vision and position data

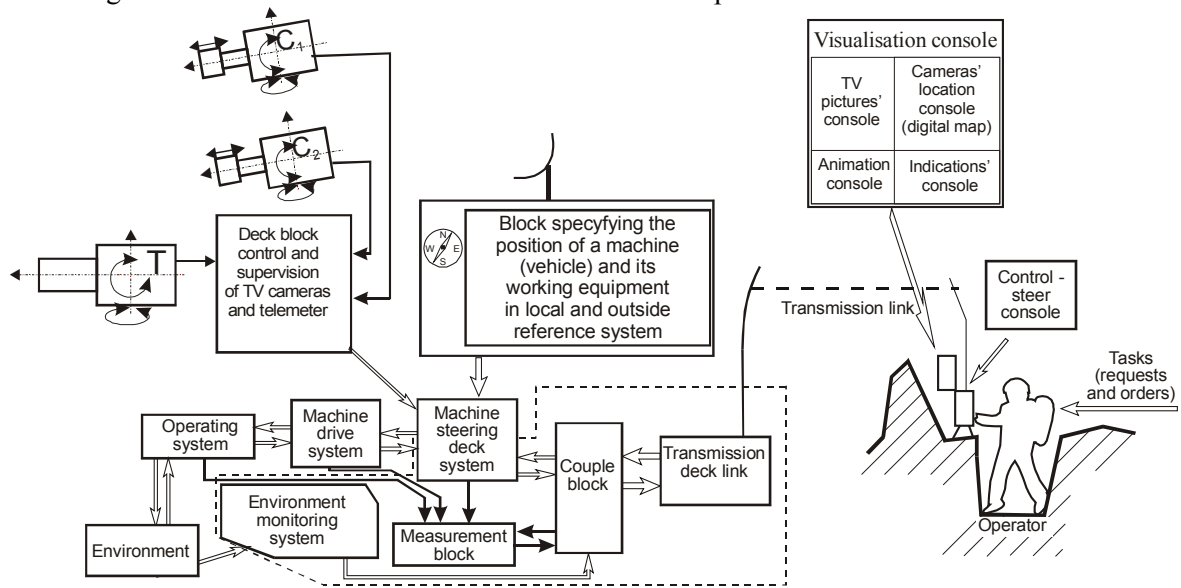

Figure 2. Structure of remote control of mobile working machines' scheme with vision system

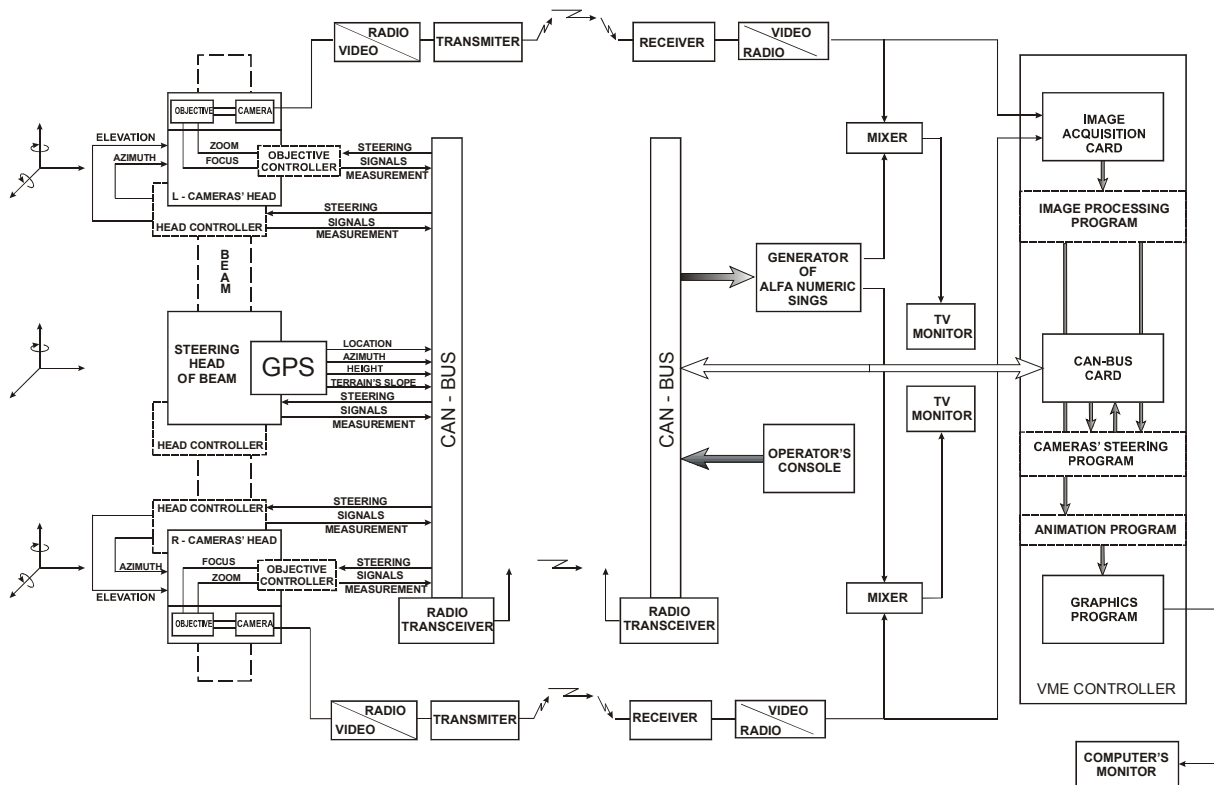

Figure 3. Scheme of vision system